

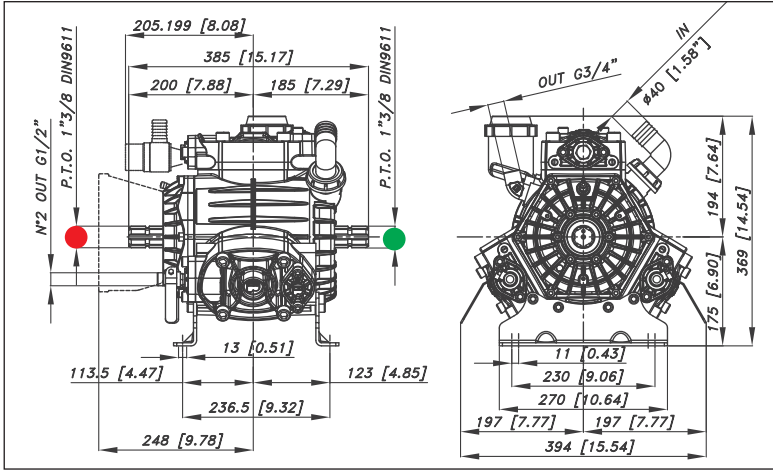

# PBO Series 1100 - 1250

## Pompa a 3 membrane-pistone semidrauliche.

Three piston semi-hydraulic diaphragm pump

Мембранно-поршневой насос с 3 полугидравлическими узлами.



Optional - Optional - По заказу   

### Caratteristiche tecniche

Specifications

Технические характеристики

<b>g/min; R.P.M.; об/мин;</b>	<b>g/min.</b>	<b>R.P.M.</b>	550	550	
<b>Peso - Weight - Вес</b>	<b>Kg</b>	<b>lb</b>	25,3	55,6	
<b>Dislivello aspirazione</b> Negative pressure Перепад уровня при всасывании	<b>MAX</b>	<b>mt</b>	<b>ft</b>	1,5	4,9
	<b>Servizio discontinuo</b> Discontinuous service - Прерывистая работа	<b>mt</b>	<b>ft</b>	3	9,8
<b>Ø Aspirazione - Ø Intake - Ø Вход</b>	<b>830</b>	<b>mm</b>	<b>in</b>	40	1" 9/16
<b>Ø Mandata - Ø High pressure - Ø Выход</b>		<b>mm</b>	<b>in</b>	6, 3/4	6, 3/4
<b>Max. Temperatura - MAX Temperature - Макс. Температура</b>		<b>°C</b>	<b>°F</b>	60	140
<b>Tipo olio - Oil type - Тип масла</b>		<b>SAE</b>	<b>W</b>	30	30
<b>Capacità olio - Oil capacity - Объем масла</b>		<b>lt</b>	<b>U.S.G.</b>	1	0,26

### ALBERO POMPA - PUMP SHAFT - ВАЛ НАСОСА



● ANT. - FRONT - ПЕР.



● POST - REAR - ЗАД.

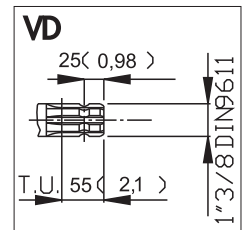
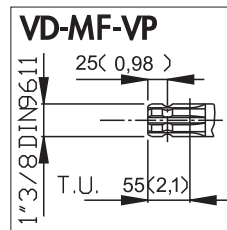

### ACCESSORI - ACCESSORIES - АКССУАРЫ



ACCESSORI D'AZIONAMENTO  
DRIVE ACCESSORIES

Pag. 105

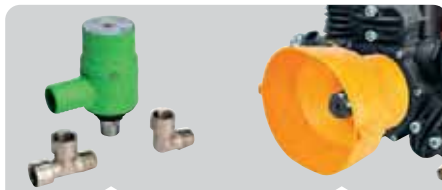

DISPOSITIVI DI SICUREZZA  
SAFETY ACCESSORIES

Pag. 106

Pag. 106



FILTRI  
FILTERS

Pag. 107

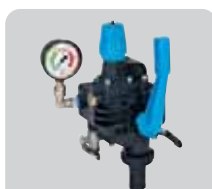

GRUPPI DI COMANDO  
CONTROL UNITS

Pag. 92



COMPUTER E PANNELLI  
COMPUTERS AND SPRAYERS CONTROL

Pag. 150



● POST - REAR - ЗАД.



● POST - REAR - ЗАД.

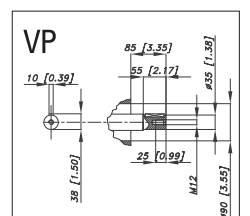
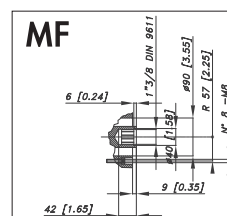

# PBO Series

## PBO 1100

**37.5065.97.3 - VD**  
**37.5066.97.3 - MF**  
**37.5067.97.3 - VP**



**110** 29,1  
l/min USGPM



**50** 725  
bar P.S.I.



**TABELLA RENDIMENTI - PERFORMANCE CHART**  
**ТАБЛИЦА ПРОИЗВОДИТЕЛЬНОСТИ**

g/min R.P.M. → об/мин;	400		450		500		550	
	L/min USGPM	KW HP	L/min USGPM	KW HP	L/min USGPM	KW HP	L/min USGPM	KW HP
<b>BAR</b>								
2	80	0,3	90	0,4	100	0,4	110	0,4
29	21,1	0,4	23,8	0,5	26,4	0,5	29,1	0,6
20	79	3,1	88,9	3,5	98,7	3,9	108,6	4,3
290	20,9	4,1	23,5	4,7	26,1	5,2	28,7	5,7
40	77,9	6,1	87,6	6,9	97,4	7,6	107,1	8,4
580	20,6	8,2	23,2	9,2	25,7	10,2	28,3	11,2
50	77,1	7,6	86,7	8,5	96,4	9,5	106	10,4
725	20,4	10,1	22,9	11,4	25,5	12,6	28	13,9

## PBO 1250

**37.5111.97.3 - VD**  
**37.5112.97.3 - MF**  
**37.5113.97.3 - VP**



**125** 33  
l/min USGPM



**50** 725  
bar P.S.I.



**TABELLA RENDIMENTI - PERFORMANCE CHART**  
**ТАБЛИЦА ПРОИЗВОДИТЕЛЬНОСТИ**

g/min R.P.M. → об/мин;	400		450		500		550	
	L/min USGPM	KW HP	L/min USGPM	KW HP	L/min USGPM	KW HP	L/min USGPM	KW HP
<b>BAR</b>								
2	90,9	0,4	102,3	0,4	113,6	0,4	125,0	0,5
29	24,0	0,5	27,0	0,5	30,0	0,6	33,0	0,7
20	89,5	3,5	100,6	4,0	111,8	4,4	123,0	4,8
290	23,6	4,7	26,6	5,3	29,5	5,9	32,5	6,5
40	88,0	6,9	99,0	7,8	110,0	8,6	121,0	9,5
580	23,2	9,2	26,2	10,4	29,1	11,5	32,0	12,7
50	87,3	8,6	98,2	9,6	109,1	10,7	120,0	11,8
725	23,1	11,4	25,9	13,9	28,8	14,3	31,7	15,7