

PBO Series 1440 - 1540

Pompa a 4 membrane-pistone semidrauliche.

Four piston semi-hydraulic diaphragm pump

Мембранно-поршневой насос с 4 полугидравлическими узлами.

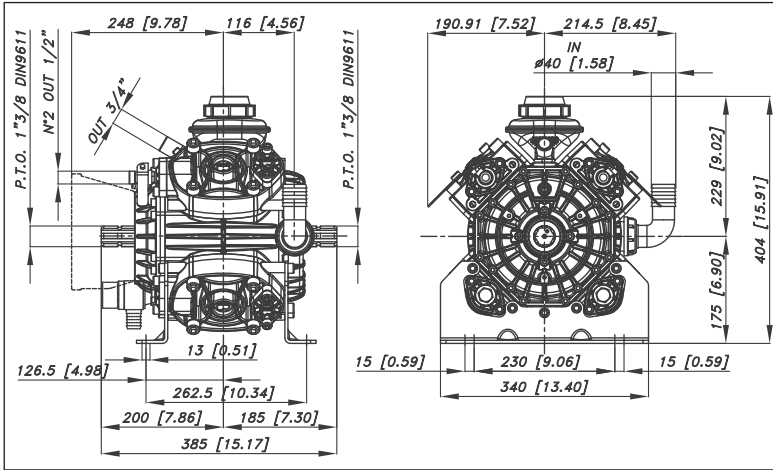

Optional - Optional - По заказу **D** **H** **V**

Caratteristiche tecniche

Specifications

Технические характеристики

g/min; R.P.M.; об/мин;	g/min.	R.P.M.	550	550	
Peso - Weight - Вес	Kg	lb	36	79	
Dislivello aspirazione Negative pressure Перепад уровня при всасывании	MAX	mt	ft	1,5	4,9
	Servizio discontinuo Discontinuous service - Прерывистая работа	mt	ft	3	9,8
Ø Aspirazione - Ø Intake - Ø Вход	930	mm	in	40	1" 9/16
Ø Mandata - Ø High pressure - Ø Выход		mm	in	6. 3/4	6. 3/4
Max. Temperatura - MAX Temperature - Макс. Температура		°C	°F	60	140
Tipo olio - Oil type - Тип масла	SAE	W	30	30	
Capacità olio - Oil capacity - Объем масла	lt	U.S.G.	1,25	0,33	

ALBERO POMPA - PUMP SHAFT - ВАЛ НАСОСА



● ANT. - FRONT - ПЕР.



● POST - REAR - ЗАД.

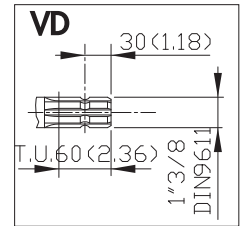
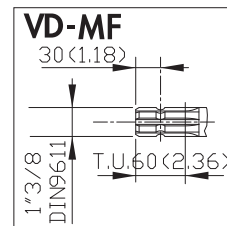

● POST - REAR - ЗАД.



● POST - REAR - ЗАД.

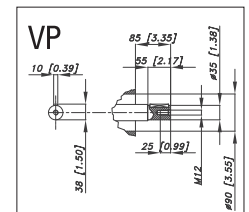
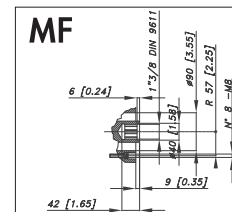

ACCESSORI - ACCESSORIES - АКССУАРЫ



ACCESSORI D'AZIONAMENTO
DRIVE ACCESSORIES

Pag. 105

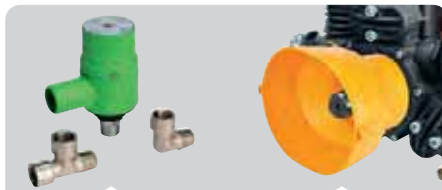

DISPOSITIVI DI SICUREZZA
SAFETY ACCESSORIES

Pag. 106



Pag. 106



FILTRI
FILTERS

Pag. 107

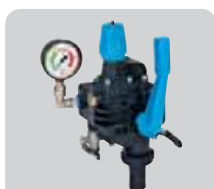

GRUPPI DI COMANDO
CONTROL UNITS

Pag. 92



COMPUTER E PANNELLI
COMPUTERS AND SPRAYERS CONTROL

Pag. 150

PBO Series

PBO 1440

41.7015.97.3 - VD
41.7016.97.3 - MF
41.7017.97.3 - VP



137 **36,2**
l/min USGPM



50 **725**
bar P.S.I.

TABELLA RENDIMENTI - PERFORMANCE CHART ТАБЛИЦА ПРОИЗВОДИТЕЛЬНОСТИ									
g/min R.P.M. → об/мин;	400		450		500		550		
	L/min USGPM	KW HP	L/min USGPM	KW HP	L/min USGPM	KW HP	L/min USGPM	KW HP	BAR P.S.I.
2	99,6	0,4	112,1	0,4	124,5	0,5	137,0	0,5	29
20	97,5	3,8	109,6	4,3	121,8	4,8	134,0	5,3	290
40	96,0	7,5	108,0	8,5	120,0	9,4	132,0	10,4	580
50	95,3	9,4	107,2	10,5	119,1	11,7	131,0	12,9	725
	26,3	0,5	29,6	0,6	32,9	0,7	36,2	0,7	
	25,7	5,1	29,0	5,8	32,2	6,4	35,4	7,0	
	25,4	10,1	28,5	11,3	31,7	12,6	34,9	13,9	
	25,2	12,5	28,3	14,1	31,5	15,6	34,6	17,2	



PBO 1540

41.7112.97.3 - VD
41.7113.97.3 - MF
41.7114.97.3 - VP



154 **40,7**
l/min USGPM



50 **725**
bar P.S.I.

TABELLA RENDIMENTI - PERFORMANCE CHART ТАБЛИЦА ПРОИЗВОДИТЕЛЬНОСТИ									
g/min R.P.M. → об/мин;	400		450		500		550		
	L/min USGPM	KW HP	L/min USGPM	KW HP	L/min USGPM	KW HP	L/min USGPM	KW HP	BAR P.S.I.
2	112,0	0,4	126,0	0,5	140,0	0,5	154,0	0,6	29
20	109,1	4,3	122,7	4,8	136,4	5,4	150,0	5,9	290
40	107,6	8,5	121,1	9,5	134,5	10,6	148,0	11,6	580
50	106,9	10,5	120,3	11,8	133,6	13,1	147,0	14,4	725
	29,6	0,6	33,3	0,7	37,0	0,7	40,7	0,8	
	28,8	5,7	32,4	6,4	36,0	7,2	39,6	7,9	
	28,4	11,3	32,0	12,7	35,5	14,1	39,1	15,5	
	28,2	14,0	31,8	15,8	35,3	17,5	38,8	19,3	

