

# PBO Series 1840



**179 47.3**  
l/min USGPM



**50 725**  
bar P.S.I.

- 41.7158.97.3 - VD** Pompa a 4 membrane-pistone semidrauliche.
- 41.7159.97.3 - MF** Four piston semi-hydraulic diaphragm pump
- 41.7160.97.3 - VP** Мембранно-поршневой насос с 4 полугидравлическими узлами.

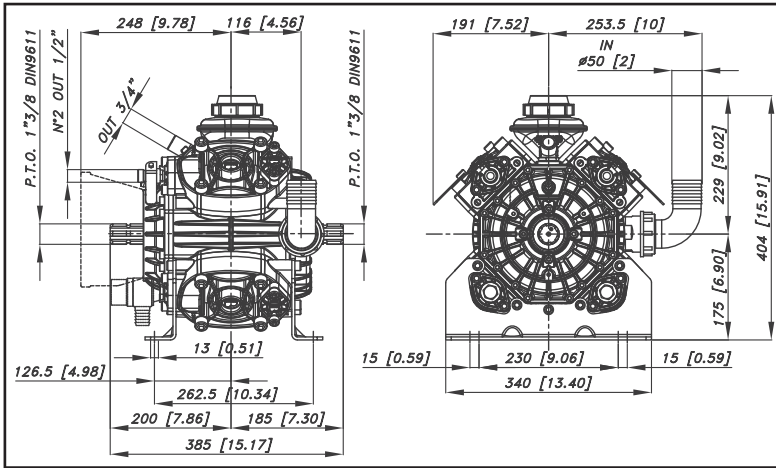

Optional - Optional - По заказу **D H V**

## Caratteristiche tecniche

Specifications

Технические характеристики

<b>g/min; R.P.M.; об/мин;</b>	<b>g/min. R.P.M.</b>	550	550
<b>Peso - Weight - Вес</b>	<b>Kg lb</b>	36	79
<b>Distivello aspirazione</b> Negative pressure Перепад уровня при всасывании	<b>MAX</b>	<b>mt ft</b>	1,5 4,9
	<b>Servizio discontinuo</b> Discontinuous service - Прерывистая работа	<b>mt ft</b>	3 9,8
<b>Ø Aspirazione - Ø Intake - Ø Вход</b>	<b>830</b>	<b>mm in</b>	50 2"
<b>Ø Mandata - Ø High pressure - Ø Выход</b>		<b>mm in</b>	G. 3/4 G. 3/4
<b>Max. Temperatura - MAX Temperature - Макс Температура</b>	<b>°C °F</b>	60	140
<b>Tipo olio - Oil type - Тип масла</b>	<b>SAE W</b>	30	30
<b>Capacità olio - Oil capacity - Объем масла</b>	<b>lt U.S.G.</b>	1,25	0,33

## TABELLA RENDIMENTI - PERFORMANCE CHART

g/min R.P.M. → об/мин;		400		450		500		550	
BAR	P.S.I.	L/min USGPM	KW HP	L/min USGPM	KW HP	L/min USGPM	KW HP	L/min USGPM	KW HP
2	29	130,2 34,4	0,5 0,7	146,5 38,7	0,6 0,8	162,7 43	0,6 0,9	179 47,3	0,7 0,9
20	290	128,7 34	5,1 6,8	144,8 38,3	5,7 7,6	160,9 42,5	6,3 8,4	177 46,8	7,0 9,3
40	580	126,5 33,4	9,9 13,3	142,4 37,6	11,2 14,9	158,2 41,8	12,4 16,6	174 46	13,7 18,3
50	725	125,1 33	12,3 16,4	140,7 37,2	13,8 18,5	156,4 41,3	15,4 20,5	172 45,4	16,9 22,6

## ACCESSORI - ACCESSORIES - АКЦЕССУАРЫ



ACCESSORI D'AZIONAMENTO  
DRIVE ACCESSORIES

Pag. 105



DISPOSITIVI DI SICUREZZA  
SAFETY ACCESSORIES

Pag. 106

Pag. 106



FILTRI  
FILTERS

Pag. 107



GRUPPI DI COMANDO  
CONTROL UNITS

Pag. 92



COMPUTER E PANNELLI  
COMPUTERS AND SPRAYERS CONTROL

Pag. 150

## ALBERO POMPA - PUMP SHAFT - ВАЛ НАСОСА

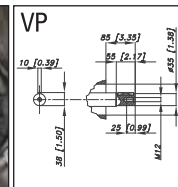
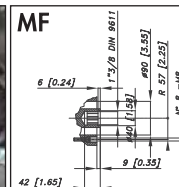
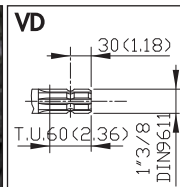
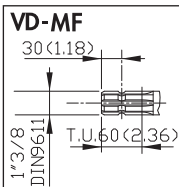

● ANT. - FRONT - ПЕР.

● POST. - REAR - ЗАД.

● POST. - REAR - ЗАД.

● POST. - REAR - ЗАД.